

МІНІСТЕРСТВО ОСВІТИ І НАУКИ УКРАЇНИ
НАЦІОНАЛЬНИЙ УНІВЕРСИТЕТ БІОРЕСУРСІВ І
ПРИРОДОКОРИСТУВАННЯ УКРАЇНИ
ІНСТИТУТ МЕХАНІКИ ТА АВТОМАТИКИ АПВ НААН
ДЕРЖАВНИЙ БІОТЕХНОЛОГІЧНИЙ УНІВЕРСИТЕТ



**ЗБІРНИК
ТЕЗ ДОПОВІДЕЙ**

*XI Міжнародної науково-технічної конференції з нагоди
117-ї річниці від дня народження
доктора технічних наук, професора,
віцепрезидента УАСГН
КРАМАРОВА
Володимира Савовича
(1906-1987)*

«КРАМАРОВСЬКІ ЧИТАННЯ»

*22-23 лютого 2024 року
м. Київ*

УДК 631.17+62-52-631.3

Збірник тез доповідей XI Міжнародної науково-технічної конференції «Крамаровські читання» з нагоди 117-ї річниці від дня народження доктора технічних наук, професора, віцепрезидента УАСГН Крамарова Володимира Савовича (1906-1987) 22-23 лют. 2024 р., м. Київ / МОН України, Національний університет біоресурсів і природокористування України. К.: Видавничий центр НУБіП України, 2024. 505 с.

Proceedings of the XI International Scientific and Technical Conference dedicated to the 117th anniversary of the birth of Doctor of Technical Sciences, Professor, Vice President of the UAAS Kramarov Volodymyr Savovych (1906–1987), February 22–23, 2024, Kyiv / MES of Ukraine, National University of Life And Environmental Sciences of Ukraine. Kyiv: Publishing center of NULES of Ukraine, 2024. 505 p.

В збірнику представлені тези доповідей науково-педагогічних працівників, наукових співробітників, аспірантів та студентів НУБіП України, провідних вітчизняних і закордонних вищих навчальних закладів та наукових установ, в яких розглядаються завершені етапи розробок.

The Proceedings presents abstracts of reports of scientific and pedagogical workers, research staff, graduate students and students of the NULES of Ukraine, leading domestic and foreign higher educational institutions and scientific institutions, in which completed stages of development are considered.

УДК 631.001.04

**TECHNICAL CONTROL OF SAFETY INDICATORS OF SELF-
PROPELLED SPRAYERS**

I. S. LIUBCHENKO, Post Graduate Student
National University of Life and Environmental Sciences of Ukraine, Ukraine
E-mail: lub4enko.ira@gmail.com

To protect the operator from crushing or cutting hazards associated with failure of the boom height adjustment control system [1], the machine must be equipped with:

- a) a device for limiting the maximum speed of the boom down to 10 mm/s during a hydraulic failure [2];
- b) a device that can stop the lowering of the rod to a minimum height of 500 mm from the ground surface [3].

For b) if the height is to be made less than 500 mm, the safety device must prevent the bar from lowering below the specified height and the lowering of the height must be possible only by means of a separate action [4].

If these safety devices are hydraulic valves not installed directly in the cylinder, the lines connecting the valve to the cylinder must be designed to withstand a pressure of not less than four times the rated maximum hydraulic pressure [5].

To limit the risk of access to the tank, any tank opening greater than 400mm in diameter, or if rectangular and greater than 400mm x 300mm, must be fitted with a grate that can only be opened using appropriate tools.

The dimensions of the holes in the grid should not be larger than those indicated above.

To limit the risk of chemical contact during filling or cleaning operations:

- a container for mixing chemicals or another equally effective device must be equipped with a nozzle;

- in addition, the filler hole of the sprayer tank should be located so that the distance from the ground or from the platform is not more than 1,300 mm, and the horizontal distance from the edge of the hole to the outer edge of any part of the sprayer that could interfere with the operator who is in place for filling, was no more than 300 mm (see Figure 1. Signs: 1 - the location of the operator during the filling of the tank.).

The actual total volume of the tank should exceed the nominal volume by at least 5%.

The cover should be:

- attached to the machine (for example, by a chain);
- equipped with a clamping device that ensures the closed position mechanically or by fastening the cover with screws;
- installed in such a way as to eliminate the possibility of leakage of the spraying solution (for example, with the help of a sealant).

The operator must be able to see the liquid level when filling or emptying the tank. The nominal volume must be indicated by marking.

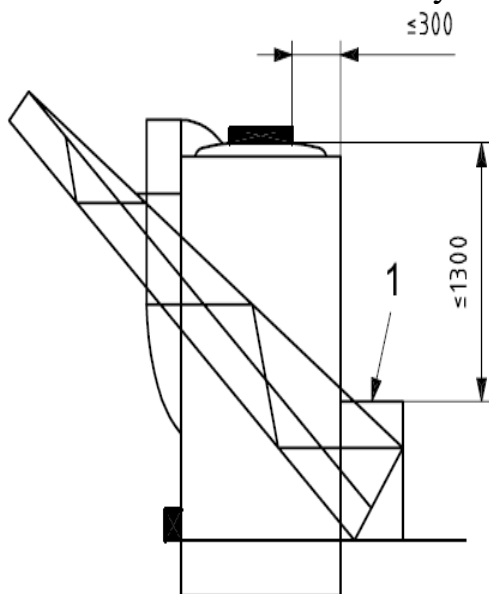

Fig. 1. Maximum reach distance for manually filling the tank with chemicals.

On tanks not intended for use under pressure, a pressure compensation device is installed to maintain atmospheric pressure in them during the emptying or filling of the tank.

References

1. Liubchenko I. S., Rogovskii I. L. Analytical provisions of the influence of completeness of technical control on the reliability of self-propelled sprayers. Bulletin of Sumy National Agrarian University. Series: mechanization and automation of production processes. 2021. Issue 1 (43). P. 14-21. <https://doi.org/10.32845/msnau.2021.1.3>.

2. Liubchenko I. S., Rogovskii I. L. Analytical coefficient of technical readiness of self-propelled sprayers with variable seasonal operating time. Scientific and technical principles of development, testing and forecasting of agricultural machinery and technologies. XXI International Scientific Conference, village Research, Ukraine, September 22, 2021: abstracts of the conference. Research. 2021. P. 71-75.

3. Liubchenko I. S., Rogovskii I. L. Safety measures in recovery of self-propelled sprayers. OSHAgro – 2021. I International Scientific and Practical Conference, Kyiv, Ukraine. September 30, 2021: abstracts of the conference. Kyiv. 2021. P. 154-157.

4. Liubchenko I. S., Rogovskii I. L. System engineering of self-propelled sprayers of Ukraine. Actual problems of practice and science and methods of their solution. IV International Scientific and Practical Conference, Milan, Italy, January 28, February 2, 2022: conference abstracts. Milan. 2022. P. 588-594.

5. Rogovskii I. L. Methodology of performance of technological operations of restoration of working capacity of agricultural machines at limited resources. Collection of abstracts of the XXII International Scientific Conference "Modern Problems of Agricultural Mechanics". October 16-18, 2021. Kyiv. Nizhyn. 2021. P. 122-125.